

100/1000BASE-T SINGLE TRANSFORMER MODULES

- ◆ Compliant with IEEE802.3 and ANSI X3.263 standards Including 350uH OCL with 8mA Bias.
- ◆ Single Channel Interface For 100/1000 Mbps Ethernet Applications
- ◆ Comply With ROHS



ELECTRICAL SPECIFICATIONS@25°C (Operating Temperature :0°C to 70°C)

Part Number	Turns Ratio ± 5%	Insertion Loss(dB max) 1-100MHz	Return Loss (dB min)				CMRR (dB min)			Cross Talk (dB min)			Hipot (vrms)
			1-30 MHz	30-60 MHz	30-60 MHz	80-100 MHz	1-30 MHz	30-60 MHz	60-100 MHz	1-30 MHz	30-60 MHz	60-100 MHz	
G18501DK-R	1:1	-1.0	-18	-14	-12	-10	-40	-35	-30	-45	-35	-30	1500

MECHANICAL

G18501DK-R

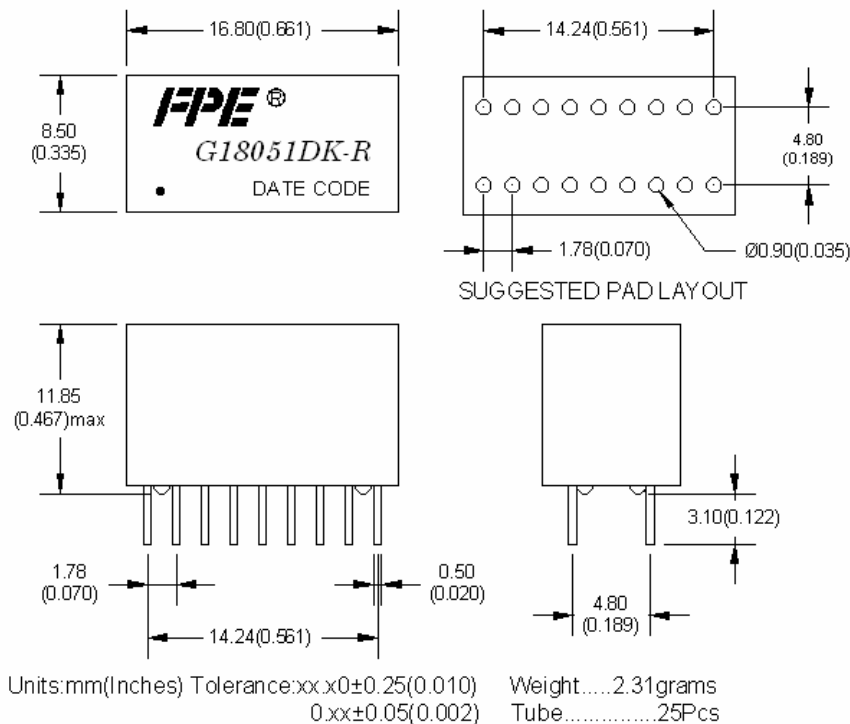

100/1000BASE-T SINGLE TRANSFORMER MODULES

SCHEMATICS

G18501DK-R

